

BWT BestMin Filter



BWT bestmin filter cartridges optimise water with a low mineral content for use in the food service sector. This often applies to water in holiday locations, for example from lakes and reservoirs and the water produced by reverse osmosis in seawater treatment plants. BWT bestmin is the perfect solution for restoring this deficiency. The balanced combination of natural minerals in the BWT bestmin filter adds the correct level of minerals to the water used in the food service sector, achieving an optimum brewing and full-taste experience for hot and cold drinks. BWT bestmin gives stale-tasting water a superb sensory quality that brings out the full flavour of hot drinks.

Features:

- Filtration system for mineralising water with a low mineral content
- Stable pH value in the filtered water prevents corrosion
- Reduces the level of 'off-flavour' elements and chlorine
- Perfect for brewed coffee and speciality coffees

Benefits of **BWT besttaste** at a glance:

- For hot and cold drinks
- Special filter protects against corrosion and residues
- Simple single-use system
- Vertical or horizontal installation
- Special BWT water+more filter for optimum water mineral content
- Innovative activated carbon fleece for full taste enjoyment

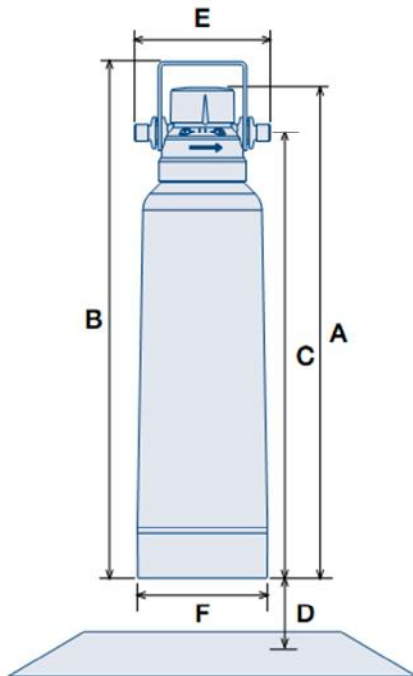

Technical Data*

bestmax type	M
Connection thread (in/out)	3/8"
Typical capacity in litres	10,000
Intake pressure, min.-max. in bar	2-8
Water temperature, min.-max. in °C	4-30
Ambient temperature, min.-max. in °C	4-40
Total height without bracket (A) in mm, approx.	475
Total height with bracket (B) in mm, approx.	500
Connection height (C) in mm	425
Distance from floor (D) in mm	65
Installed length (E) in mm	125
Filter cartridges Ø (F) in mm	130
Weight in g without filter head	3,800
Order No. Installation Set	FS24M01A00
Order No. Filter Cartridge	FS24M00A00

*Subject to change without notice

